

Technical Data	
Heater power	2x11.0kW 4.7W/cm <sup>2</sup>
Voltage	2x400V 50Hz 3NAC
Fuse	2 x (3x16A)
Mains connection	3L+N+PE L=1.5m(2. cable)
Weight	
Capacity (max.)	2x1.5 kg
Capacity (rec.)	2x1.25 kg
Capacity / hour	2x30-35kg precooked chips
Oil capacity	2 x 13-16 liter

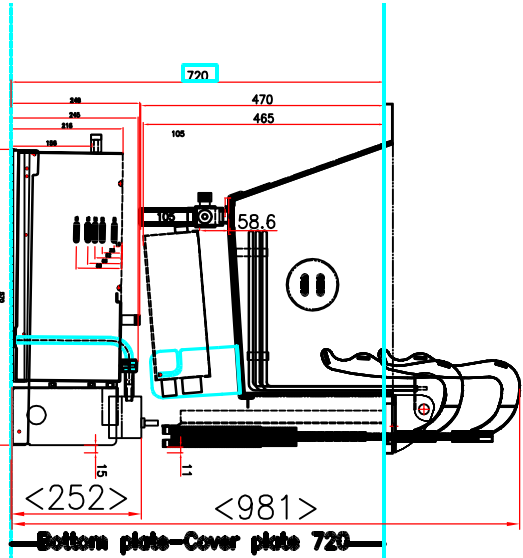

720/700 with pump system  
Advanced built-in devices VXE  
(special height upon request)

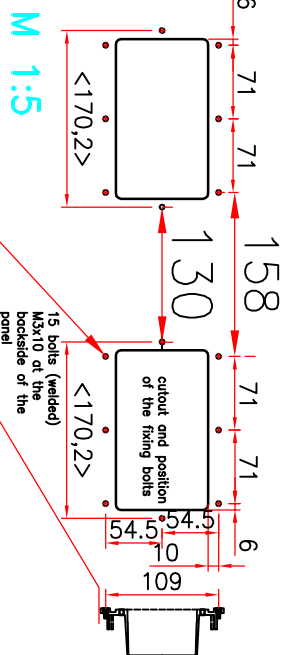
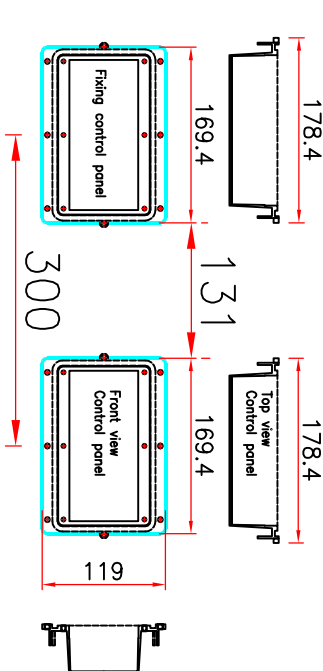

Options:

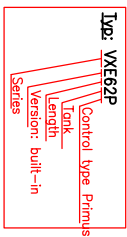

F = Filter and pump system

L1 = 1xLift

L2 = 2xLift

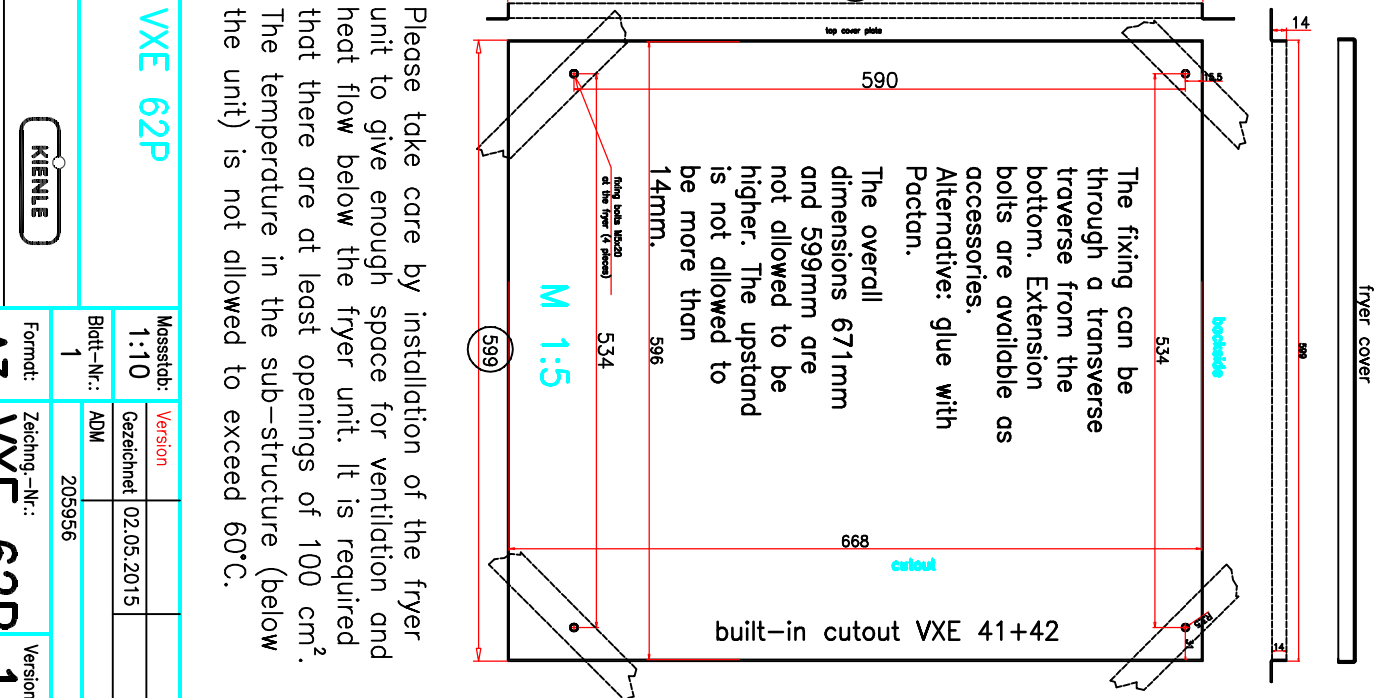

Please take care by installation of the fryer unit to give enough space for ventilation and heat flow below the fryer unit. It is required that there are at least openings of 100 cm<sup>2</sup>. The temperature in the sub-structure (below the unit) is not allowed to exceed 60°C.

### built-in fryer VXE 62P

Model VXE 62P

Kienle GmbH Fritter-Technologie  
D-72469 Messstetten-Hornheim  
Telefon 07579 920-0  
Telefax 07579 920-20



Messstab:	Version
1:10	Gezeichnet 02.05.2015
Blatt-Nr.: 1	ADM
205956	
Format: A3	Zeichung-Nr.: VXE 62P 1
Version	1

Technical subject to alteration!  
Version 30.06.2020